



# Product Specifications

<b>Customer</b>	<b>Standard</b>
<b>Description</b>	<b>2.7" TFT EPD Panel</b>
<b>Model Name</b>	<b>EM027AS012</b>
<b>Date</b>	<b>2013/06/24</b>
<b>Doc. No.</b>	<b>1P033-00</b>
<b>Revision</b>	<b>02</b>

<b>Customer Approval</b>	
<b>Date</b>	
The above signature represents that the product specifications, testing regulation, and warranty in the specifications are accepted	

	<b>Design Engineering</b>		
	<b>Approval</b>	<b>Check</b>	<b>Design</b>
			

No.71, Delun Rd., Rende Dist., Tainan City 71743, Taiwan (R.O.C.)

Tel: +886-6-279-5399

Fax: +886-6-279-5300

## Copyright

Pervasive Displays Incorporated All rights reserved.

This document is the exclusive property of Pervasive Displays Inc. (PDI) and shall not be reproduced or copied or transformed to any other format without prior permission of PDI. ( PDI Confidential )

本資料為龍亭新技股份有限公司專有之財產，非經許可，不得複製、翻印或轉變成其他形式使用。

龍亭新技股份有限公司 Pervasive Displays Inc.

No.71, Delun Rd., Rende Dist., Tainan City 71743, Taiwan (R.O.C.)

Tel: +886-6-279-5399

<http://www.pervasivedisplays.com>

PERVASIVE DISPLAYS INC.

## Table of Contents

Revision History .....	6
Glossary of Acronyms .....	7
1 General Description .....	8
1.1 Overview.....	8
1.2 Features .....	8
1.3 Applications .....	8
1.4 General Specifications .....	9
1.5 Mechanical Specifications .....	10
2 Absolute Maximum Ratings.....	12
2.1 Absolute Ratings of Environment .....	12
2.2 Reliability Test Item .....	13
3 Electrical Characteristics .....	14
3.1 Absolute Maximum Ratings of Panel .....	14
3.2 Recommended Operation Conditions of Panel .....	14
4 Application Circuit Block Diagram .....	16
5 Terminal Pin Assignment & Reference Circuit.....	17
5.1 Terminal Pin Assignment .....	17
5.2 Reference Circuit.....	19
6 Optical Characteristics .....	20
6.1 Test Conditions .....	20
6.2 Optical Specifications .....	20
6.2.1 Optical.....	20
6.2.2 Ghosting .....	23
7 Packing .....	24
8 Precautions .....	26
9 Definition of Labels.....	28

**List of Figures**

Figure 1-1 EPD Drawing..... 11

Figure 2-1 Operating Range of Relative Humidity and Temperature ..... 12

Figure 3-1 Test Pattern of Panel ..... 15

Figure 3-2 Image Update Current Profile ..... 15

Figure 3-3 Current Measurement ..... 15

Figure 4-1 Application Circuit Block Diagram..... 16

Figure 5-1 EPD Reference Circuit ..... 19

Figure 6-1 Optical measurement..... 21

Figure 6-2 Definition of Viewing Angle to Measure Contrast Ratio..... 22

Figure 7-1 Packing Diagram ..... 24

Figure 9-1 Model Labels..... 28

Figure 9-2 Definition of Model Labels..... 28

Figure 9-3 Carton Label ..... 29

Figure 9-4 Pallet Label..... 29

PERVASIVE DISPLAYS INC

**List of Tables**

Table 1-1 General Specification .....9

Table 1-2 Mechanical Specification ..... 10

Table 1-3 FPC Specification ..... 10

Table 2-1 Absolute Ratings of Environment..... 12

Table 2-2 Reliability Test Items ..... 13

Table 3-1 Absolute Maximum Ratings of Panel..... 14

Table 3-2 Recommended Operation Conditions of Panel..... 14

Table 5-1 Terminal Pin Assignment ..... 17

Table 6-1 Optical Test Conditions ..... 20

Table 6-2 Optical Measurement with D65 light source ..... 20

Table 6-3 Measurement of Ghosting ..... 23

PERVASIVE DISPLAYS INC.

## Revision History

Version	Date	Page (New)	Section	Description
Ver.01	2012/06/30	All	All	Product specification first issued.
Ver.02	2013/06/24	1	Cover page	Modify company address and Fax number.
		2		
		11	1	Modify EPD drawing
		13	2.2	Add Note 3 at Reliability Test Items
		15	3.2	Add current value(MAX) Add Note description
		17	5.1	Modify description in Terminal Pin Assignment
		19	5.2	Modify Reference circuit
		23	6.2.2	About refreshing of Test1 & Test2 had modified "1h storage" to "Refresh immediately", and to delete the PCS test.
28	9	Modify definition of labels		
29				

## Glossary of Acronyms

EPD	Electrophoretic Display (e-Paper Display)
EPD Panel	EPD
EPD Module	EPD with TCon board
TCon	Timing Controller
TFT	Thin Film Transistor
MCU	Microcontroller Unit
FPC	Flexible Printed Circuit
FPL	Front Plane Laminate
SPI	Serial Peripheral Interface
COG	Chip on Glass
PCS	Print Contrast Signal
PDI	Pervasive Displays Incorporated

PERVASIVE DISPLAYS INC.

# 1 General Description

## 1.1 Overview

This is a 2.7" a-Si, active matrix TFT, Electronic Paper Display (EPD) panel. The panel has such high resolution (117 dpi) that it is able to easily display fine patterns. Due to its bi-stable nature, the EPD panel requires very little power to update and needs no power to maintain an image.

## 1.2 Features

- a-Si TFT active matrix Electronic Paper Display(EPD)
- Resolution: 264 x 176
- Ultra low power consumption
- Super Wide Viewing Angle - near 180°
- Extra thin & light
- SPI interface
- RoHS compliant

## 1.3 Applications

- Electronic shelf label (ESL)
- Reusable container
- Badge



## 1.4 General Specifications

**Table 1-1 General Specification**

Item	Specification	Unit	Note
Outline Dimension	70.42(H) x 45.80(V) x 1.00(T)	mm	(1)
Active Area	57.288(H) x 38.192(V)	mm	
Driver Element	a-Si TFT active matrix	-	
FPL	V110	-	
Pixel Number	264 x 176	pixel	
Pixel Pitch	0.217 x 0.217 (117dpi)	mm	
Pixel Arrangement	Vertical stripe	-	
Display Colors	Black/White	-	
Surface Treatment	Anti-Glare	-	

Note (1): Not including the FPC.

PERVASIVE DISPLAYS INC.

## 1.5 Mechanical Specifications

**Table 1-2 Mechanical Specification**

Item		Min.	Typ.	Max.	Unit	Note
Glass Size	Horizontal(H)	70.12	70.42	70.72	mm	
	Vertical(V)	45.50	45.80	46.10	mm	
	Thickness(T)	0.80	1.00	1.20	mm	(1)
Weight		-	6.30	7.7	g	

Note (1): Not including the Masking Film.

**Table 1-3 FPC Specification**

Item	Pin numbers	Pitch (mm)	Connector	Note
Golden Finger	40	0.5	STARCONN 089H40 or Compatible	

**Figure 1-1 EPD Drawing**

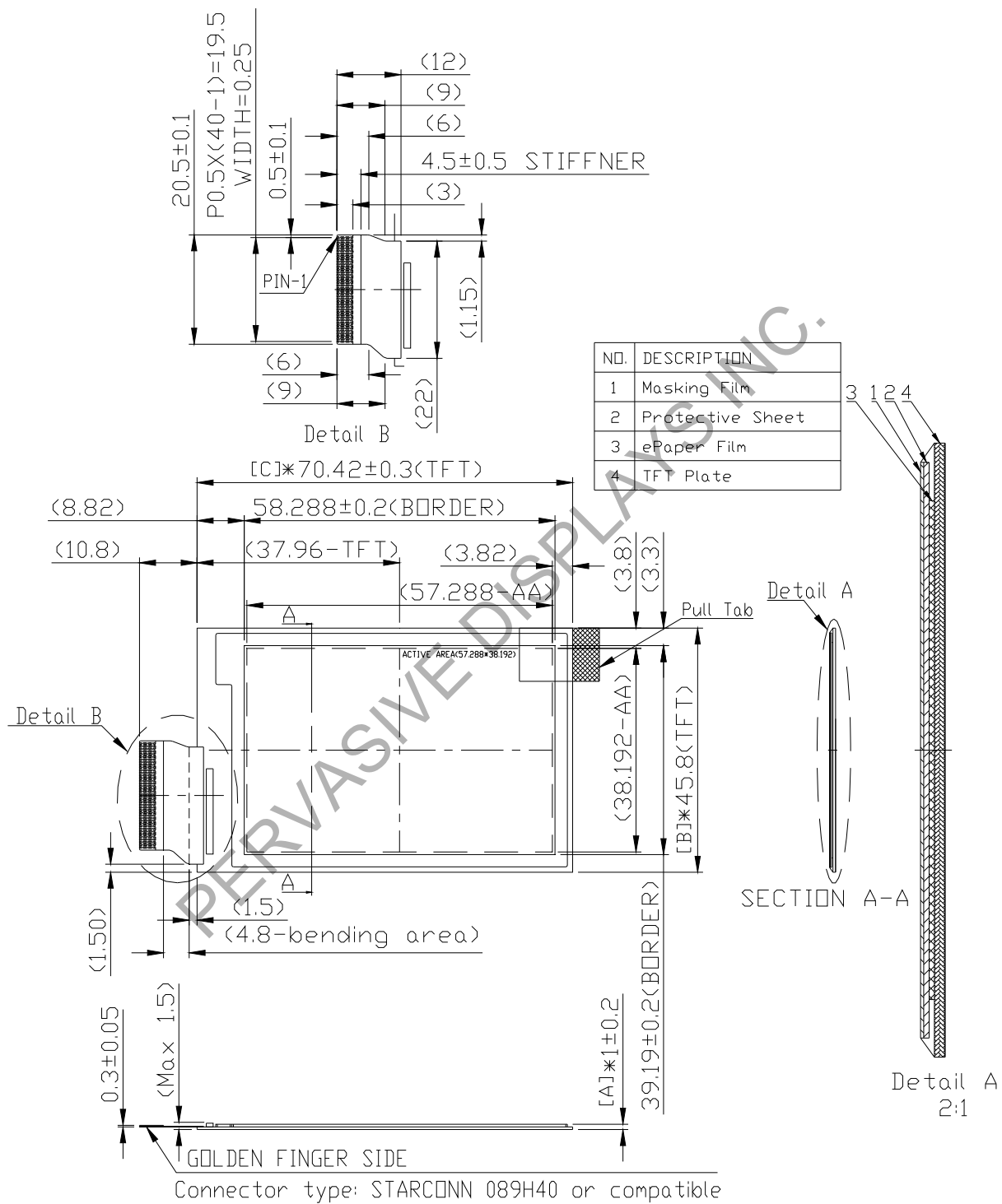

**General tolerance:  $\pm 0.3\text{mm}$**

## 2 Absolute Maximum Ratings

### 2.1 Absolute Ratings of Environment

Table 2-1 Absolute Ratings of Environment

Item	Symbol	Value		Unit	Note
		Min.	Max.		
Storage Temperature	T <sub>ST</sub>	-20	+60	°C	(1)
Operating Ambient Temperature	T <sub>OP</sub>	0	+50	°C	(1), (2)

Note (1):

- (a) 90 %RH Max. ( $T_a \leq 40$  °C), where  $T_a$  is ambient temperature.
- (b) Wet-bulb temperature should be 39 °C Max. ( $T_a > 40$  °C).
- (c) No condensation.

Note (2): The temperature of panel display surface area should be 0 °C Min. and 50 °C Max. Refresh time depends on operation temperature.

Figure 2-1 Operating Range of Relative Humidity and Temperature

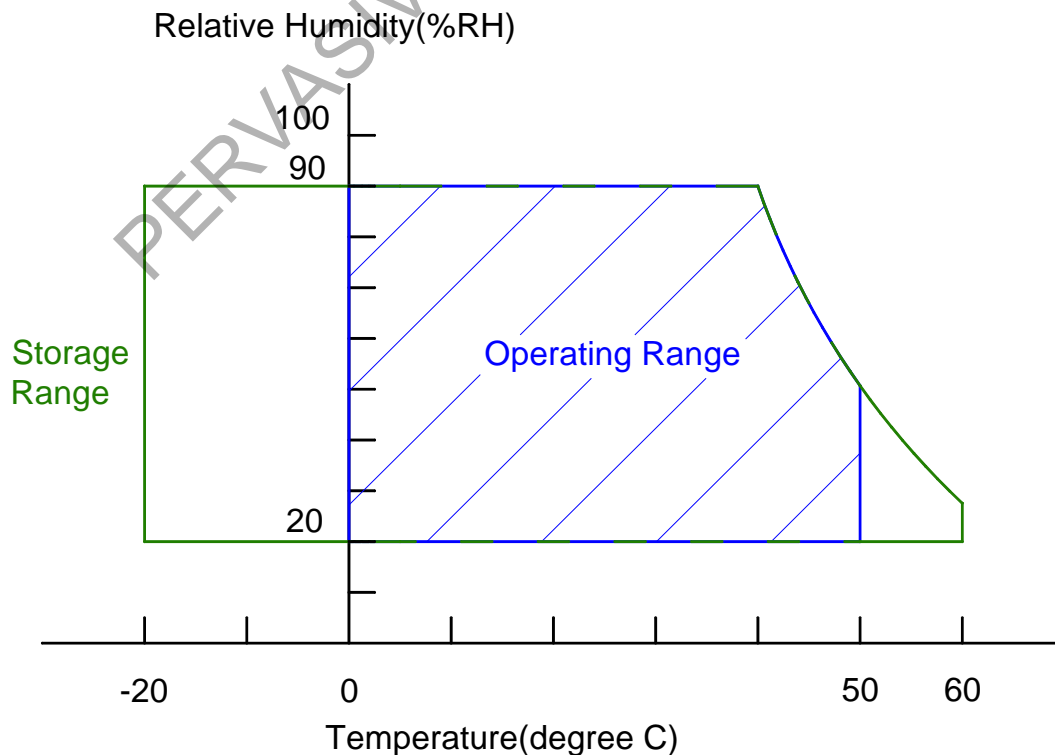

## 2.2 Reliability Test Item

**Table 2-2 Reliability Test Items**

Item	Test Condition	Note
High Temperature Operation	50 °C for 240h	(1) (2)
Low Temperature Operation	0 °C for 240h	(1) (2)
High Temperature/Humidity Operation	40 °C / 90%RH for 168h	(1) (2)
High Temperature Storage	60 °C for 240h	(1)(2)(3)
Low Temperature Storage	-20 °C for 240h	(1)(2)(3)
High Temperature/Humidity Storage	50 °C / 80% RH for 168h	(1)(2)(3)
Temperature Shock ( Storage )	-20 °C/30 min ~ 60°C/30min for 100 cycles	(1)(2)(3)
Package Drop Test	Drop from 97cm. ( ISTA ) 1 corner, 3 edges, 6 sides. One drop for each.	(1)(2)(3)
Package Random Vibration Test	1.15Grms, 1Hz ~ 200Hz. ( ISTA )	(1)(2)(3)

Note (1): End of test, function, mechanical, and optical shall be satisfied.

Note (2): The test result and judgment are based on PDI's 1bit driving waveform, driving fixture and driving system.

Note (3): Test with white pattern

### 3 Electrical Characteristics

#### 3.1 Absolute Maximum Ratings of Panel

Table 3-1 Absolute Maximum Ratings of Panel

Parameter	Symbol	Value		Unit	Note
		Min	Max		
Digital Power	$V_{DD}$	-0.3	5.0	V	
Analog Power	$V_{CC}$	-0.3	5.0	V	
Ground	$V_{SS}$	-		-	Connect $V_{SS}$ to Ground

$T_a = 25 \pm 2 \text{ }^\circ\text{C}$

#### 3.2 Recommended Operation Conditions of Panel

Table 3-2 Recommended Operation Conditions of Panel

Parameter	Symbol	Value			Unit	Note
		Min	Typ	Max		
Digital Power	$V_{DD}$	2.7	3.0	3.3	V	
Analog Power	$V_{CC}$	2.7	3.0	3.3	V	
Input Voltage	High	$V_{IH}$	$0.8V_{DD}$	-	$V_{DD}$	/CS, ID, SCLK, SI, /RESET
	Low	$V_{IL}$	$V_{SS}$	-	$0.2V_{DD}$	
Output Voltage	High	$V_{OH}$	$0.8V_{DD}$	-	$V_{DD}$	$I_{OH}=0.5\text{mA}$ , SO, BUSY
	Low	$V_{OL}$	$V_{SS}$	-	$0.2V_{DD}$	$I_{OL}=-0.5\text{mA}$ , SO, BUSY
Input Leakage Current	High	$I_{IH}$	-	-	1.0	$\mu\text{A}$
	Low	$I_{IL}$	-	-	-1.0	$\mu\text{A}$

Input Current(RMS)	$I_{DD} + I_{CC}$	-	6	10	mA	(1),(2),(3)
DC/DC Inrush Current	$I_{PEAK}$	-	40	100	mA	(1),(2),(3)

$T_a = 25 \pm 2 \text{ } ^\circ\text{C}$

Note (1):

**Figure 3-1 Test Pattern of Panel**



These currents are tested with PDI test jig.

Note (2):

$V_{DD} = V_{CC} = 3.0\text{V}$

**Figure 3-2 Image Update Current Profile**

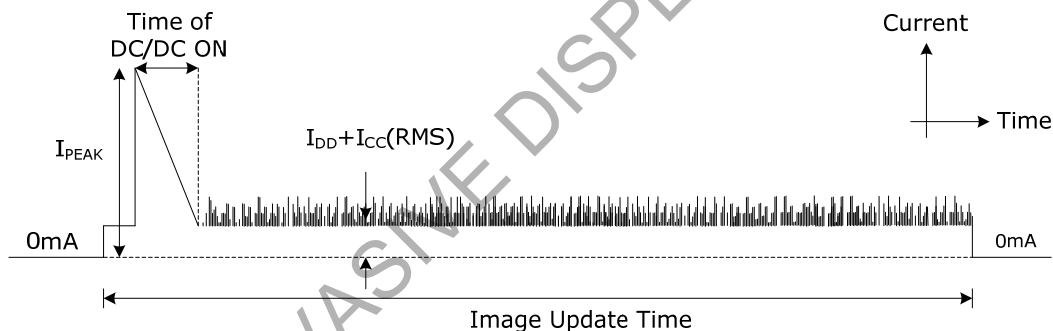

The "Time of DC/DC ON" which contains the some current peak of  $V_{GH}/V_{DH}/V_{GL}/V_{DL}/V_{COM}$ .

Note (3):

**Figure 3-3 Current Measurement**

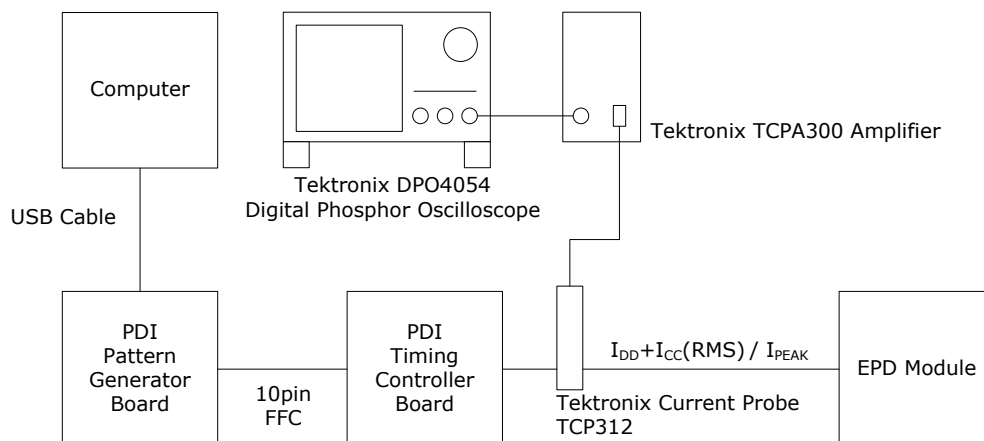

## 4 Application Circuit Block Diagram

Figure 4-1 Application Circuit Block Diagram

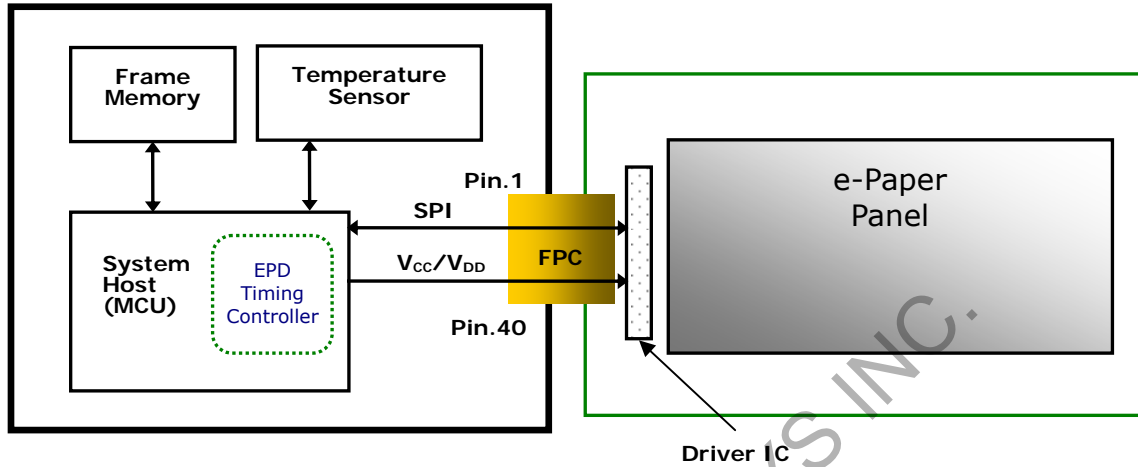

PERVASIVE DISPLAYS INC.



## 5 Terminal Pin Assignment & Reference Circuit

### 5.1 Terminal Pin Assignment

Table 5-1 Terminal Pin Assignment

No.	Signal	Type	Connected to	Function
1	/CS	I	Tcon	Chip Select. Low enable
2	BUSY	O	Tcon	When BUSY = HIGH, EPD stays in busy state that EPD ignores any input data from SPI
3	ID	I	Ground	Connect ID to ground
4	SCLK	I	Tcon	Clock for SPI
5	SI	I	Tcon	Serial input from Timing Controller to EPD
6	SO	O	Tcon	Serial output from EPD to Timing Controller
7	/RESET	I	Tcon	Reset signal. Low enable
8	ADC_IN	-	-	Not connected
9	V <sub>CL</sub>	C	Capacitor	-
10	C42P	C	Charge-Pump Capacitor	-
11	C42M	C		-
12	C41P	C	Charge-Pump Capacitor	-
13	C41M	C		-
14	C31M	C	Charge-Pump Capacitor	-
15	C31P	C		-
16	C21M	C	Charge-Pump Capacitor	-
17	C21P	C		-
18	C16M	C	Charge-Pump Capacitor	-
19	C16P	C		-
20	C15M	C	Charge-Pump Capacitor	-
21	C15P	C		-

22	C14M	C	Charge-Pump Capacitor	-
23	C14P	C		-
24	C13M	C	Charge-Pump Capacitor	-
25	C13P	C		-
26	C12M	C	Charge-Pump Capacitor	-
27	C12P	C		-
28	C11M	C	Charge-Pump Capacitor	-
29	C11P	C		-
30	V <sub>COM_DRIVER</sub>	RC	Resistor & Capacitor	The signal duty cycle can drive V <sub>COM</sub> voltage from source driver IC
31	V <sub>CC</sub>	P	V <sub>CC</sub>	Power supply for analog part of source driver
32	V <sub>DD</sub>	P	V <sub>DD</sub>	Power supply for digital part of source driver
33	V <sub>SS</sub>	P	Ground	-
34	V <sub>GH</sub>	C	Capacitor	-
35	V <sub>GL</sub>	C	Capacitor	-
36	V <sub>DH</sub>	C	Capacitor	-
37	V <sub>DL</sub>	C	Capacitor	-
38	BORDER	I	-	Connect to V <sub>DL</sub> via control circuit for white frame border
39	V <sub>ST</sub>	P	V <sub>COM_PANEL</sub>	-
40	V <sub>COM_PANEL</sub>	C	Capacitor	V <sub>COM</sub> to panel

Note:

- Type: I: Input
- O: Output
- C: Capacitor
- RC: Resistor and Capacitor
- P: Power

## 5.2 Reference Circuit

Figure 5-1 EPD Reference Circuit

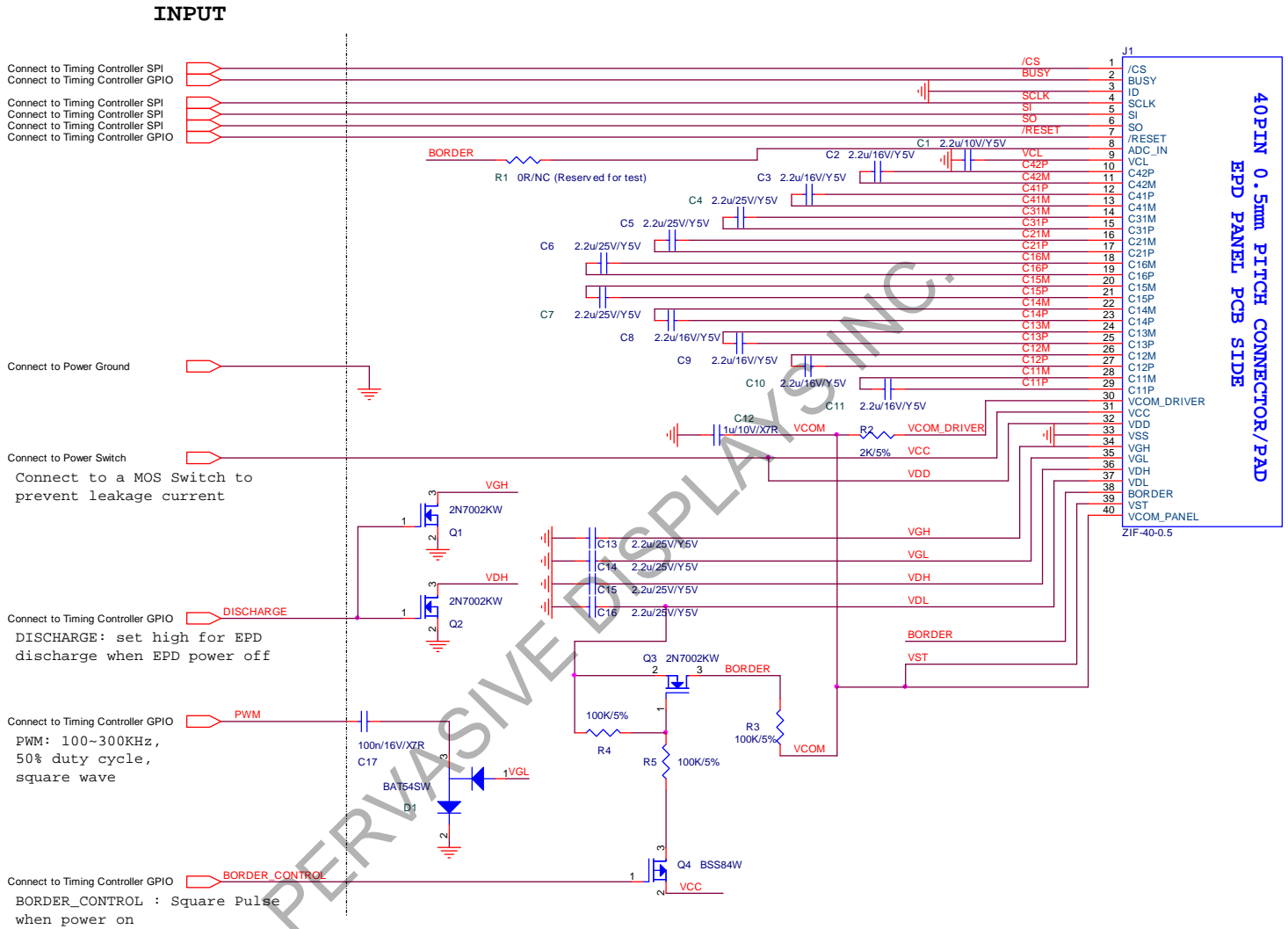

Note: (1)  $V_{DD}$  and  $V_{CC}$  must be discharged promptly after power off.

## 6 Optical Characteristics

### 6.1 Test Conditions

Table 6-1 Optical Test Conditions

Item	Symbol	Value	Unit
Ambient Temperature	Ta	25±2	°C
Ambient Humidity	Ha	50±10	%RH
Supply Voltage	V <sub>CC</sub> & V <sub>DD</sub>	3.0	V

### 6.2 Optical Specifications

#### 6.2.1 Optical

Table 6-2 Optical Measurement with D65 light source

Item	Symbol	Rating			Unit	Note
		Min.	Typ.	Max.		
Contrast ratio	CR	5:1	7:1	-	-	$\theta_x=\theta_y=0$ (1),(2),(3),(4)
Refresh time	Tr	-	3	-	sec	(3)
White Chromaticity	Wx	-	0.313	-	-	$\theta_x=\theta_y=0$ (1),(4)
	Wy	-	0.338	-		
Reflectance	R%	25	32	-	%	(1),(4)

Note (1): Panel is driven by PDI waveform without masking film and optical measurement by CM-700D with D65 light source and SCE mode.

Figure 6-1 Optical measurement

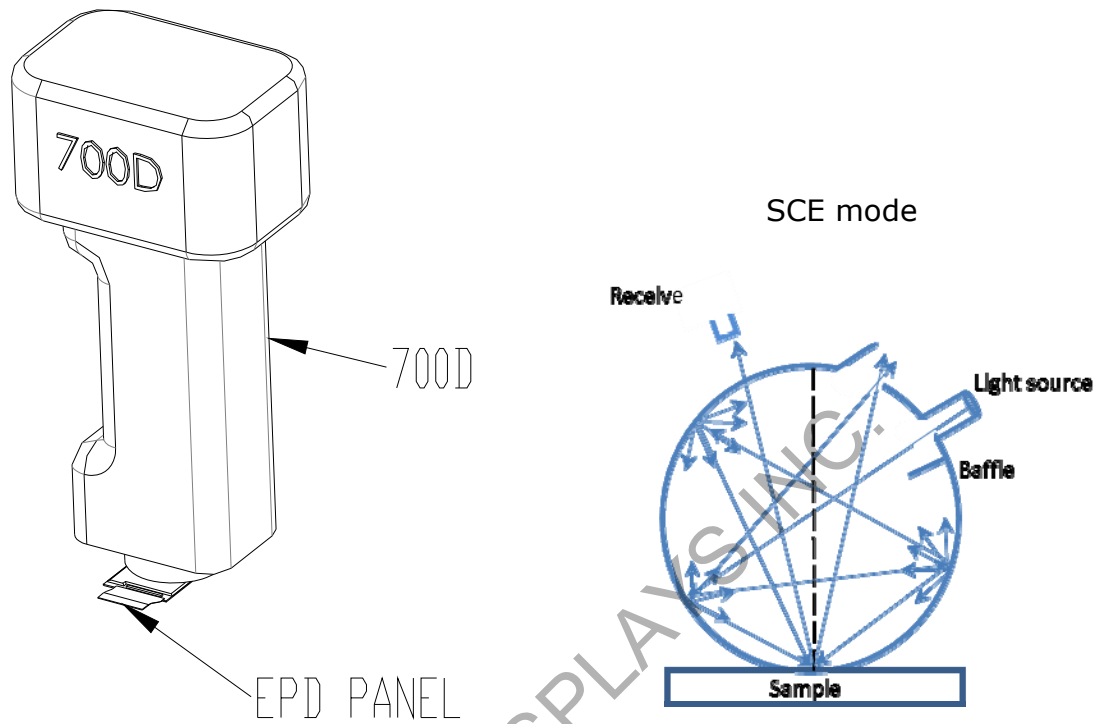

PERVASIVE DISPLAYS INC.

Note (2): Definition of Viewing Angle ( $\theta_x$ ,  $\theta_y$ ):

Figure 6-2 Definition of Viewing Angle to Measure Contrast Ratio

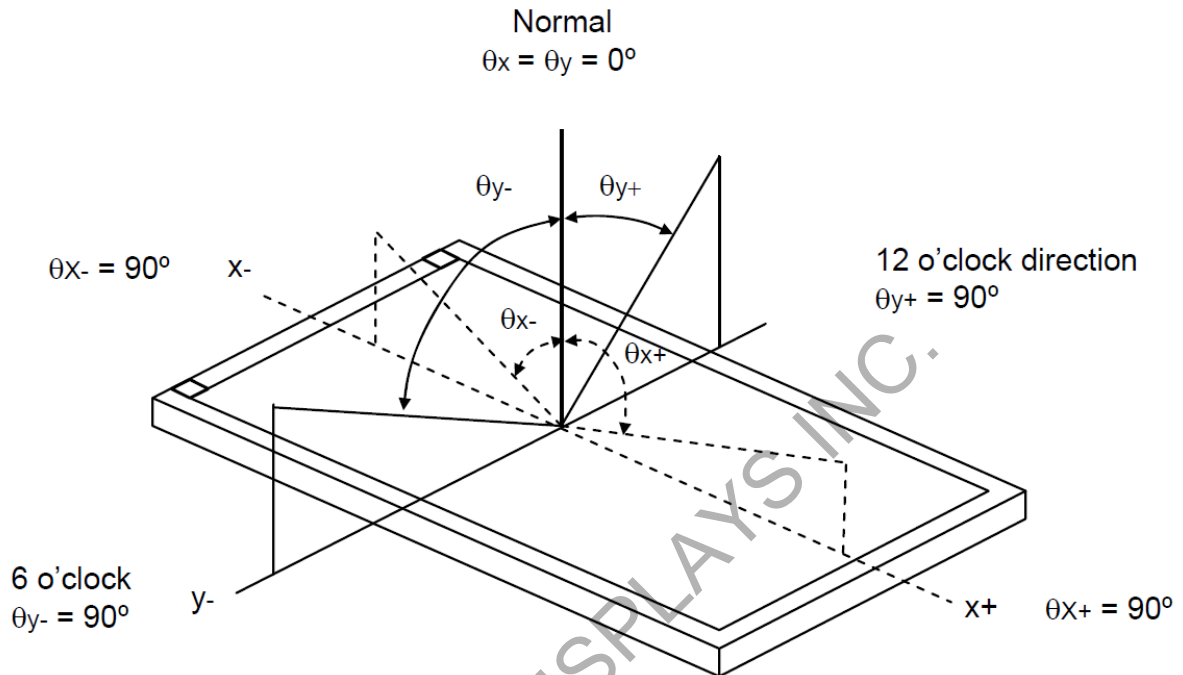

Note (3): Refresh time is the time that e-paper particles move not including the power on and off time. The refresh time is measured at 25°C. The refresh time and contrast ratio varies due to different films, display performance requirements, and ambient temperatures.

Note (4): Contrast ratio (C.R.): The Contrast ratio is calculated by the following expression.  $C.R. = (R\% \text{ White}) / (R\% \text{ Black})$ . Reflectance is measured at 120 seconds after refresh.

### 6.2.2 Ghosting

Below are two test methods to verify that ghosting within an acceptable range. Test 1 and Test 2 use measured data to calculate Delta E which is a single number representing the distance between two colors in a 3 dimensional color space. Test 1, 2 are performed at 25°C.

- Test 1: White to Black Ghosting

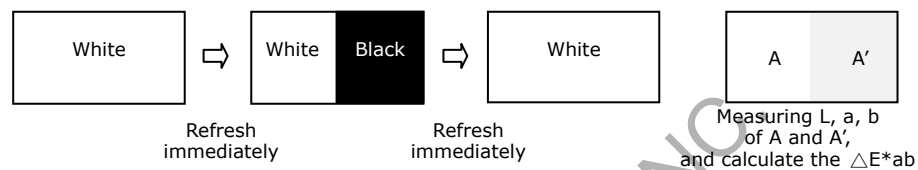

- Test 2: Black to White Ghosting

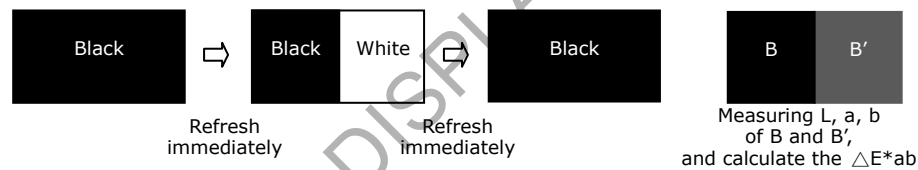

The formula is used to calculate Test1 and Test2. For example of Test 2:

$$\Delta E^*ab = [ (L_B - L_{B'})^2 + (a_B - a_{B'})^2 + (b_B - b_{B'})^2 ]^{1/2}$$

**Table 6-3 Measurement of Ghosting**

Item	Rating		
	Min.	Typ.	Max.
Test 1 ΔE*ab	-	-	2
Test 2 ΔE*ab	-	-	2

Note: Panel is driven by PDI waveform without masking film and optical measurement by CM-700D with D65 light source and SCE mode.

## 7 Packing

Figure 7-1 Packing Diagram

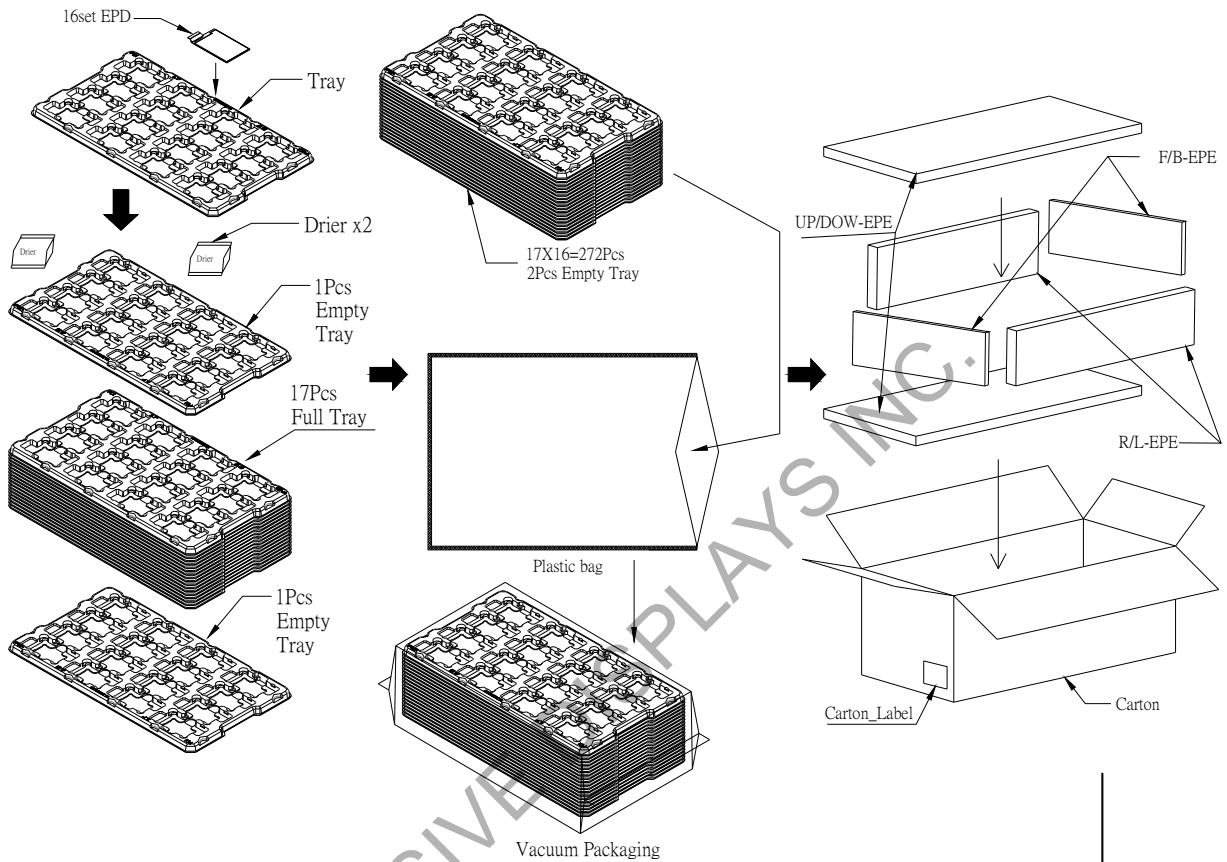

- Note:
1. Carton outline size: 500L X 300W X 200H mm
  2. Material of tray: A-PET
  3. Material of plastic bag: PE-LD

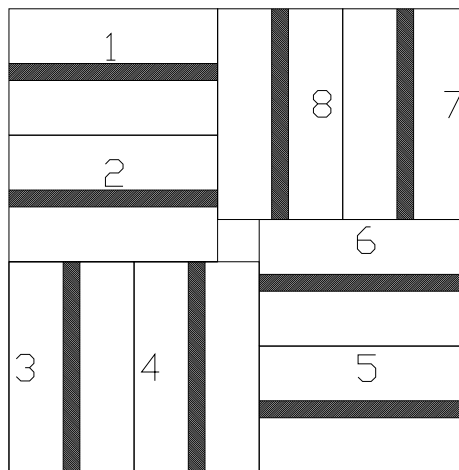



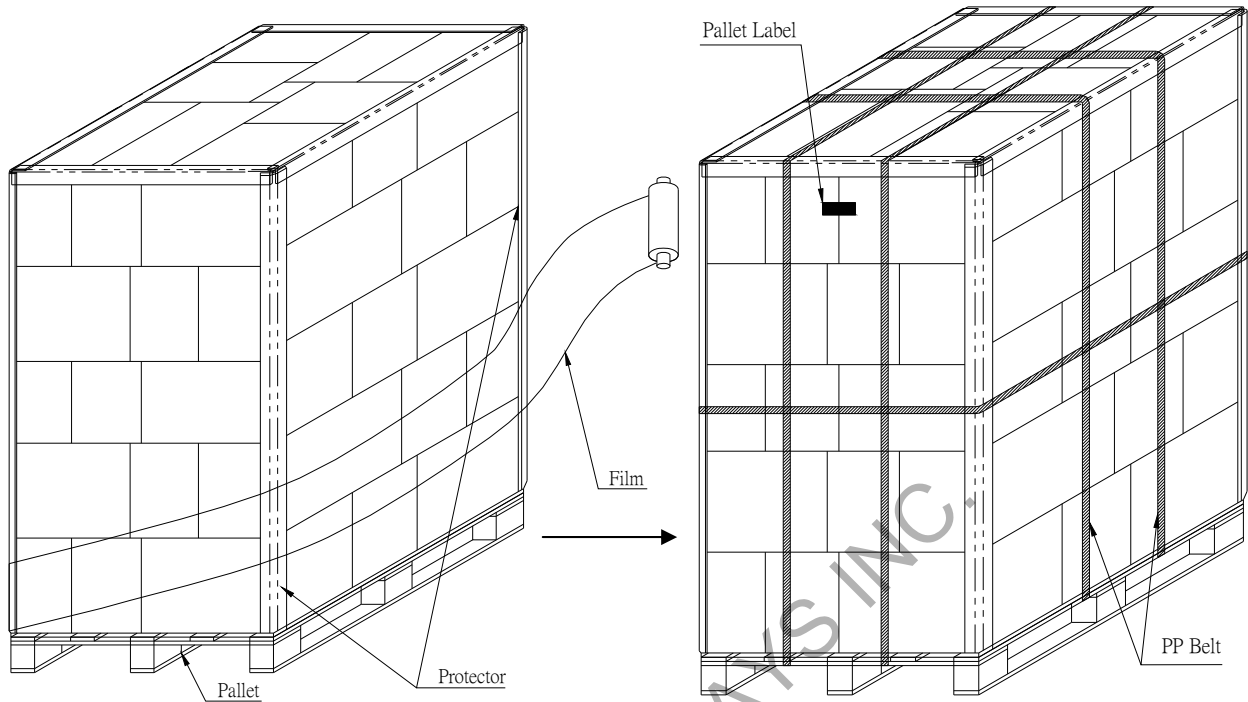

272(pcs) x 40(BOX)=10,880pcs

	2.7" EPD BOX
N.W. :	1.71 Kg
G.W. :	5.08 Kg

## Sea / Land / Air Transportation

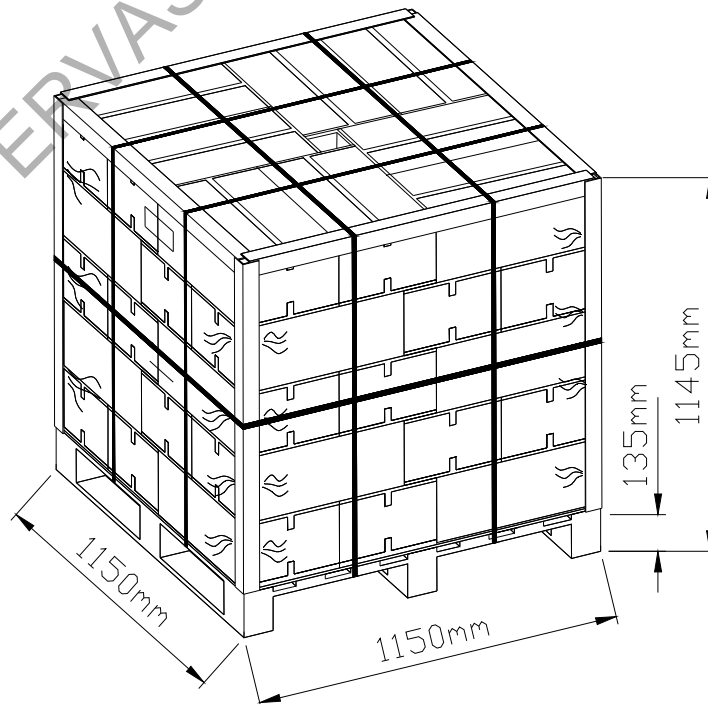

## 8 Precautions

- (1) The EPD Panel / Module is manufactured from fragile materials such as glass and plastic, and may be broken or cracked if dropped. Please handle with care. Do not apply force such as bending or twisting to the EPD panel during assembly.
- (2) It is recommended to assemble or install EPD panels in a clean working area. Dust and oil may cause electrical shorts or degrade the protection sheet film.
- (3) Do not apply pressure to the EPD panel in order to prevent damaging it.
- (4) Do not connect or disconnect the interface connector while the EPD panel is in operation.
- (5) Please support the bezel with your finger while connecting the interface cable such as the FPC.
- (6) Do not stack the EPD panels / Modules.
- (7) Do not press the FPC on the glass edge or Pull FPC up / down to 90°.
- (8) Do not touch the FPC lead connector.
- (9) Wear a Wrist Strap (Grounding connect) when handling and during assembly. Semiconductor devices are included in the EPD Panel / Module and they should be handled with care to prevent any electrostatic discharge (ESD). (An Ion Fan may be needed in assembly operation to reduce ESD risk.)
- (10) Keep the EPD Panel / Module in the specified environment and original packing boxes when storage in order to avoid scratching.
- (11) Do not disassemble or reassemble the EPD panel.
- (12) Use a soft dry cloth without chemicals for cleaning. The surface of the protection sheet film is very soft and easily scratched.
- (13) Be mindful of moisture to avoid its penetration into the EPD panel, which may cause damage during operation.
- (14) High temperature, high humidity, sunlight or fluorescent light may degrade the EPD panel's performance. Please do not expose the unprotected EPD panel to high temperature, high humidity, sunlight, or fluorescent for long periods of time. It is highly recommended to store the EPD panel in a dark place without condensation, a temperature range of 15°C to 35°C, and humidity from 30%RH to 60%RH.
- (15) The ink used for marking the Panel ID number is erased easily by solvent. Please avoid using solvent to clean the EPD panel.
- (16) The EPD is vacuum packed.
- (17) Before approved by PDI and customer, products and product specifications may be subject to change without notice. Confirm that you have received the latest product standards or specifications before final design, purchase or use.
- (18) PDI makes every attempt to ensure that its products are of high quality and reliability. However, contact PDI sales office before using the product in an application that demands especially high quality and reliability or where its failure or malfunction may directly threaten human life or cause risk of bodily injury, such as aerospace, aeronautics, nuclear power, combustion control, transportation, traffic, safety equipment or medical equipment for life support.

- (19) Design your application so that the product is used within the ranges guaranteed by PDI particularly for maximum rating, operating supply voltage range, heat radiation characteristics, installation conditions and other characteristics. PDI bears no responsibility for failure or damage when used beyond the guaranteed ranges. Even within the guaranteed ranges, consider normally foreseeable failure rates or failure modes in semiconductor devices and employ systemic measures such as fail safes, so that the equipment incorporating PDI product does not cause bodily injury, fire or other consequential damage due to operation of the PDI product.
- (20) This product is not designed to be radiation resistant.

PERVASIVE DISPLAYS INC.

## 9 Definition of Labels

Figure 9-1 Model Labels

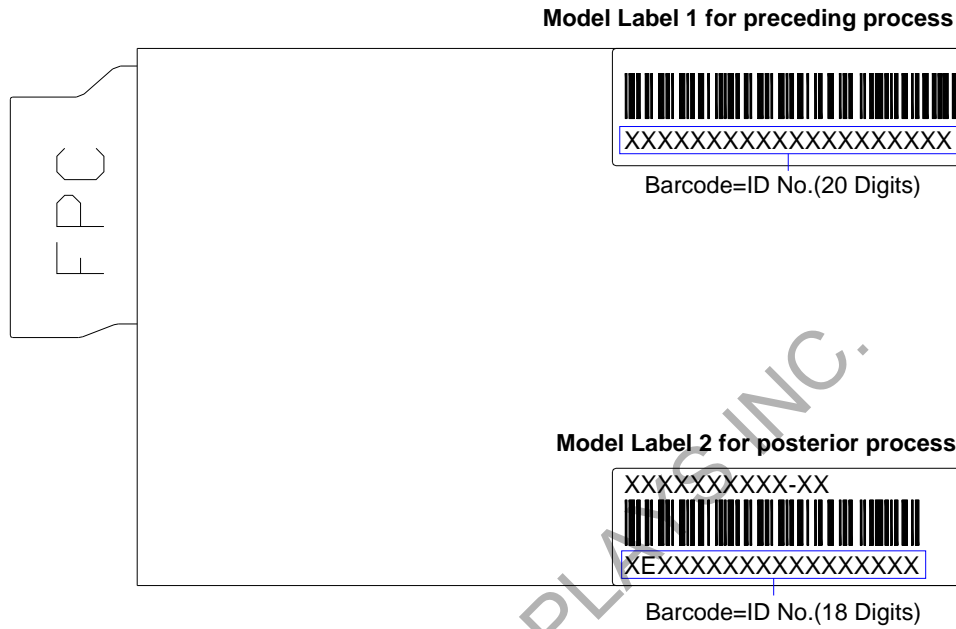
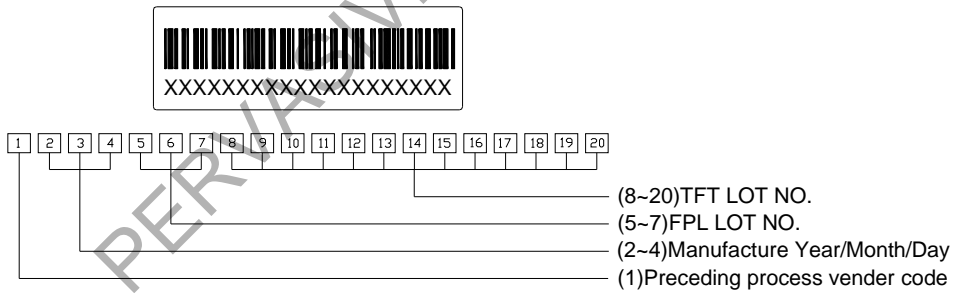

Figure 9-2 Definition of Model Labels

### ID NO. definition of Model Label 1



### ID NO. definition of Model Label 2

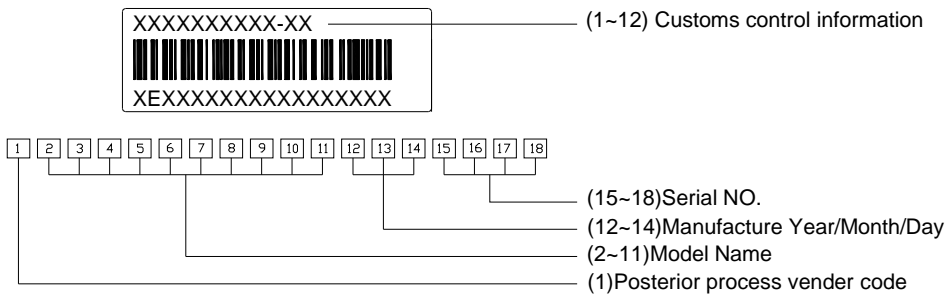
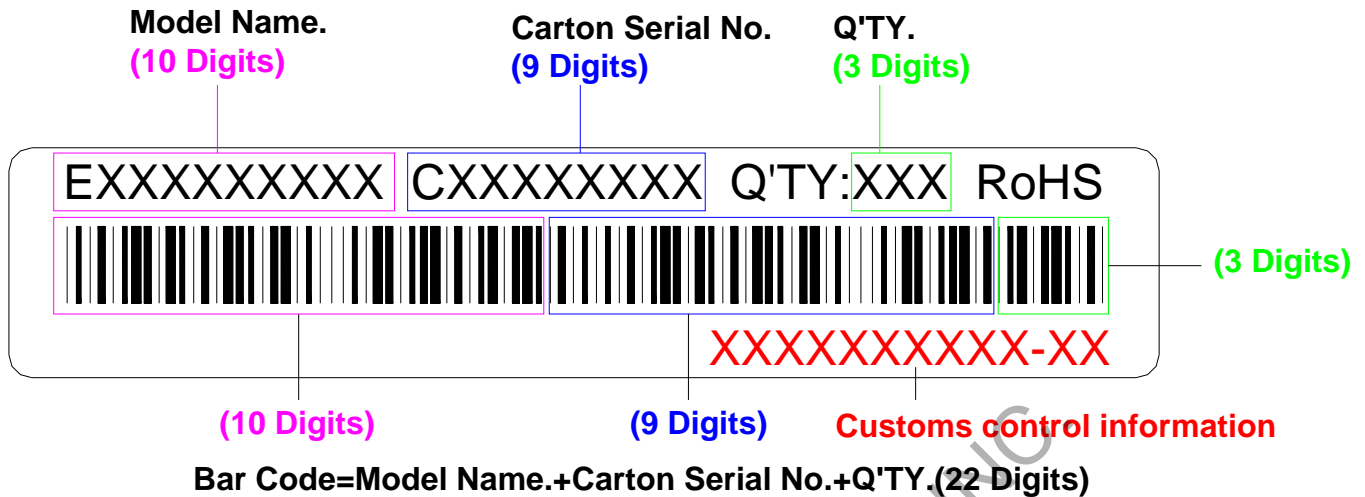

Figure 9-3 Carton Label



# Carton Label

Figure 9-4 Pallet Label



Bar Code=Model Name.+Pallet Serial No.+Q'TY.(22 Digits)

# Pallet Label